

GAA-350-90 CNC

GAA-500-90 CNC

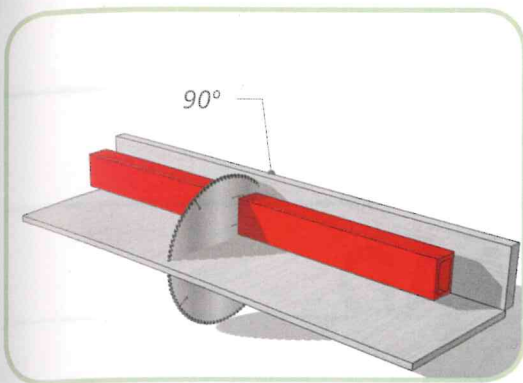



GAA-600-90 CNC

GAA-650-90 CNC

GAA-800-90 CNC

Especificaciones / Specification

| Modelo | GAA-350-90 CNC | GAA-500-90 CNC | GAA-600-90 CNC | GAA-650-90 CNC | GAA-800-90 CNC |
|---|---|---|---|---|--|
| Motor / Motor | 2,5 Hp / 2 Kw | 4,0 Hp | 5,5 Hp / 4 Kw | 7,5 Hp / 5,5 Kw | 10 Hp / 7,5 Kw |
| Diámetro max. sierra / Blade saw diameter | 350 mm | 500 mm | 600 mm | 650 mm | 800 mm |
| Velocidad sierra / Blade saw speed | 3000 rpm | 3000 rpm | 3000 rpm | 3000 rpm | 3000 rpm |
| Diámetro del eje / Blade saw axis diameter | 32 mm | 50 mm | 50 mm | 50 mm | 50 mm |
| Altura máx. de corte / Max. cutting height | 100 mm | 150 mm | 225 mm | 252 mm | 320 mm |
| Recorrido alimentador / Feeder advance range | 700 mm (múltiples avances) 700 mm (multiple advances) | 700 mm (múltiples avances) 700 mm (multiple advances) | 700 mm (múltiples avances) 700 mm (multiple advances) | 700 mm (múltiples avances) 700 mm (multiple advances) | 700 mm (múltiples avances) 700 mm (multiple advances) |
| Pisadores neumáticos / Pneumatic Clamps | 6 (3 Horiz. - 3 Vert.) | 6 (3 Horiz. - 3 Vert.) | 6 (3 Horiz. - 3 Vert.) | 6 (3 Horiz. - 3 Vert.) | 6 (3 Horiz. - 3 Vert.) |
| Sistemas de lubricación / Lubrication systems | Neumática mediante pulverizador. Pneumatic with Spray. | Neumática mediante pulverizador. Pneumatic with Spray. | Neumática mediante pulverizador. Pneumatic with Spray. | Neumática mediante pulverizador. Pneumatic with Spray. | Micropulverización Lubetools Micro spraying Lubetools |
| Dimensiones / Dimensions | 1500x1400x970 mm | 2050x1150x990 mm | 2020x1510x975 mm | 2020x1610x975 mm | 2200x1730x975 mm |
| Peso / Weight | 350 Kg | 470 Kg | 650 Kg | 720 Kg | 980 Kg |
| <input type="radio"/> 90° | 100 mm | 150 mm | 225 mm | 250 mm | 320 mm |
| <input type="checkbox"/> 90° | 100x100 mm | 150x150 mm | 200x200 mm | 225x225 mm | 275x275 mm |
| <input type="checkbox"/> 90° | 170x60 mm | 250x75 mm | 300x175 mm | 300x200 mm | 375x225 mm |

Tronzadora para el corte de perfiles de aluminio con CNC.

- Ciclo automático.
- Alimentador automático de 700 mm. con husillo de bolas motorizado.
- Programador OMRON.
- 10 programas de 30 líneas.
- 20 referencias por programa.
- Parada de emergencia.
- Velocidad de alimentación y corte regulables.
- Longitud con múltiples avances.
- Corte a 90°.
- Refrigeración automática aire-aceite.
- Funcionamiento semiautomático o totalmente automático.

PARA DIFERENTES PROGRAMACIONES Y MECANIZACIONES, CONSÚLTENOS.

Automatic CNC controlled circular saw for cutting and drilling aluminium.

- Automatic cycle.
- 700 mm ballscrew feeder.
- OMRON controller.
- 10 programs with 30 lines.
- 20 parts in memory.
- Emergency stop.
- Adjustable feeding and cutting speeds.
- Automatic adjusted cutting length with multiple advances.
- Cut to 90°.
- Automatic air-oil cooling.
- Semi-automatic or fully automatic operation.

ASK US FOR DIFFERENT SETTINGS.